

4

3

2

REVISIONS				
ZONE	REV	DESCRIPTION	DATE	APPROVED

D

D

C

C

B

B

A

A

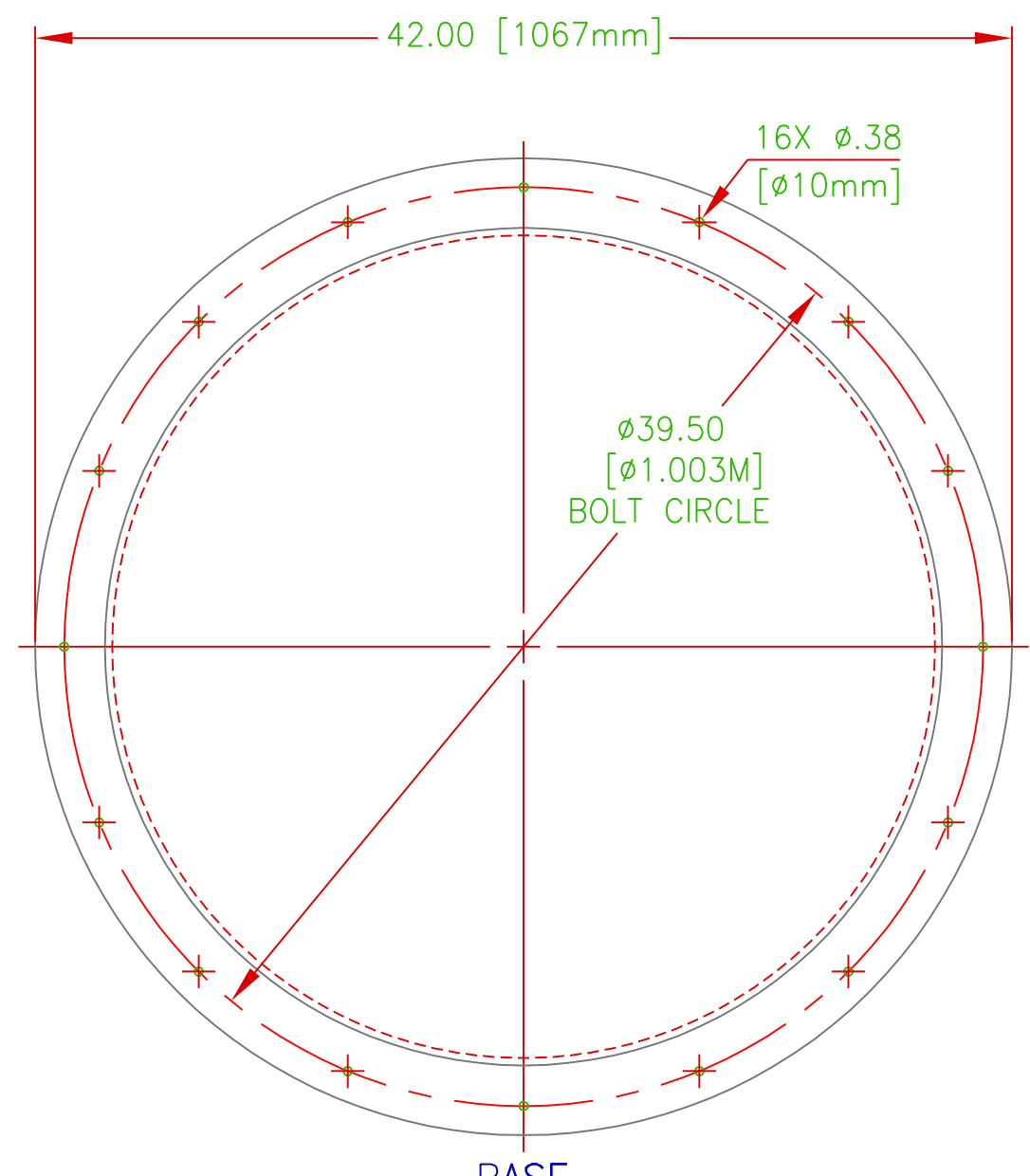
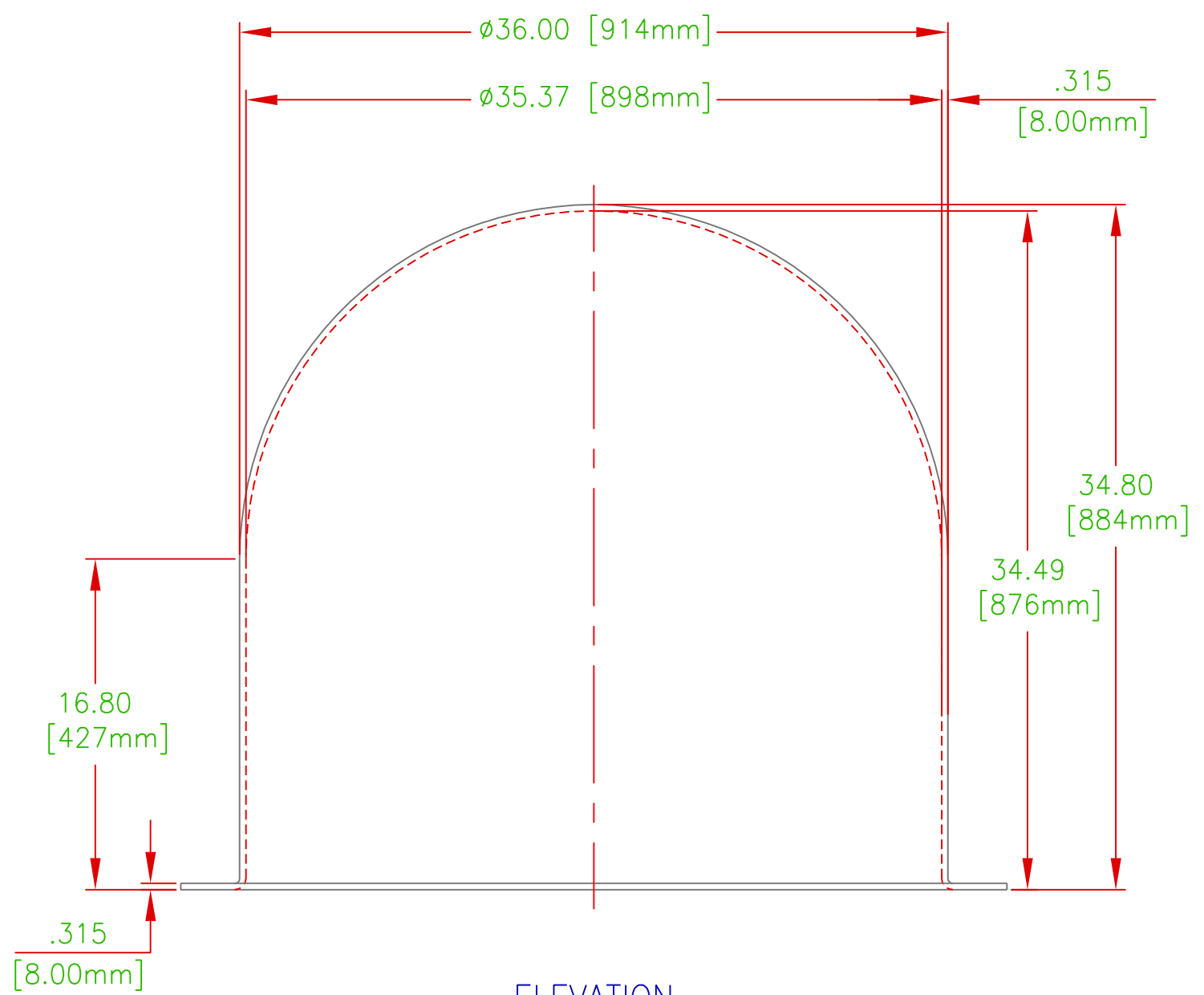

These documents by Antennas for Communications contain information of a proprietary nature and shall not be copied or duplicated in whole or in part or used in whole or in part for any purpose other than for preparation of bids or fabrication.

1. ALL MACHINED SURFACES TO BE 125 MICRONS OR SMOOTHER.	2. ALL DIMENSIONS ARE IN INCHES.
.X $\pm .1$ [2.5mm]	FRACTIONS $\pm 1/16$
.XX $\pm .04$ [1.0mm]	ANGLE $\pm 1^\circ$
.XXX $\pm .008$ [0.2mm]	
R. POSNER DESIGN 05/22/06	S. SPIVEY PRODUCTION 05/22/06
R.VANDERLAAN QUALITY 05/22/06	

OUTLINE SPECIFICATIONS			
3' RADOME 2.9' HIGH			
AFC		3DPT2.9004	
ANTENNAS FOR COMMUNICATIONS INC. OCALA, FLORIDA			
SIZE B	CAGE CODE IGC56	DWG NO. 3DPT2.9002	REV. A
R. KROHNE DRAWN BY 05/22/06		SCALE 1:8	SHEET 1 OF 1

4

3

2

1